

VL FLEX 52MM SERIES

INTELLIGENT BATTERY MONITOR KIT

USER MANUAL
rev. AB



EN

DE

IT

FR

ES

PT

CONTENT

- CONTENT 2**
- INTRODUCTION 3**
 - Packaging Content 3
 - Benefits of Using the Battery Monitoring System..... 3
 - Design and Function 3
 - The All-In-One Instrument..... 4
 - Contactless Configuration 4
- SAFETY INFORMATION 5**
 - Safety During Installation 5
 - Safety After Installation..... 6
 - Electrical Connection 6
- MECHANICAL INSTALLATION 7**
 - Before the Assembly 7
 - Installation with Spinlock..... 8
 - Flush Mounting..... 9
- ELECTRICAL INSTALLATION 10**
 - Pinout 10
 - Wiring – 12V Variant..... 10
 - Wiring – 24V Variant..... 11
 - Installation Guide..... 12
- CONFIGURATION..... 15**
 - Intelligent Battery Monitor App..... 15
 - System Configuration 16
 - Supported Configurations..... 18
 - Time for Valid SOC and SOH..... 18
 - External Charging of the Battery..... 18
- DISPLAY LAYOUT 19**
 - Screen Carousel..... 19
 - Charge Display 21
 - Alarm Display 21
- TECHNICAL DATA..... 22**
 - Datasheet..... 22
- ACCESSORIES..... 23**

INTRODUCTION

PACKAGING CONTENT

12V-Version

| Part Number | Description |
|---------------|--|
| B000847 | 1x VL Flex 52 IBM Gauge 12V |
| B00084201 | 1x Intelligent Battery Sensor (IBS) 12 V |
| B00068401 | 1x Battery Pole Adapter M6 |
| B000868 | 1x Wire Harness 12 V IBS 6m |
| A2C5205947101 | 1x 52 mm Mounting Spinlock |
| B000875 | 1x Push Button for Wire Harness |
| B000100 | 1x Safety instructions |

24V-Version

| Part Number | Description |
|---------------|--|
| B000848 | 1x VL Flex 52 IBM Gauge 24V |
| B00072101 | 1x Intelligent Battery Sensor (IBS) 24 V |
| B00068201 | 1x Battery Pole Adapter M8 |
| B000869 | 1x Wire harness 24 V IBS 6m |
| A2C5205947101 | 1x 52 mm Mounting Spinlock |
| B000875 | 1x Push Button for Wire Harness |
| B000100 | 1x Safety Instructions |

BENEFITS OF USING THE BATTERY MONITORING SYSTEM

The Intelligent Battery Monitoring System informs you about the current energy status, allowing you to plan your energy supply. This makes it the key element of the vehicle's energy management.

By using the Intelligent Battery Monitoring System, the energy management system can react quickly in case of critical battery state which influences both the consumer behaviour and the alternator.

It delivers real time measurements during the charging/discharging processes, preventing phenomena like over charging or over temperature which can lead to a shortened lifespan of your batteries.

DESIGN AND FUNCTION

The IBS is attached directly to the negative pole of the battery via its pole terminal.

Alongside the terminal, the mechanical portion of the battery sensor consists of the shunt and grounding bolt.

The shunt is attached to the vehicle's load path and is used as a measuring resistor to measure the current indirectly.

THE ALL-IN-ONE INSTRUMENT

The VL Flex device can easily be configured to be the instrument you need – thanks to its sun-readable 1.44” TFT display embedded into a standard 52 mm instrument housing.

The supported analog inputs allow you to directly read from your level sensors and the Intelligent Battery Sensor can be read through the LIN 2.0 interface.

The simple but effective graphic design can be set up in a single or dual layout, presenting the data in a clear and intuitive form, while the colored bar graph and the alarm display allow you to visually understand your data.

CONTACTLESS CONFIGURATION

Thanks to the contactless configuration you can setup your all-in-one instrument with a simple tap!

Launch the companion App and define your settings through the user-friendly interface, then simply hold your mobile device in proximity of the VL Flex device to transfer the configuration.

Thanks to the embedded passive antenna the configuration can be done without powering up the device!



SAFETY INFORMATION

WARNING

- No smoking! No open fire or heat sources!
- The product was developed, manufactured and inspected according to the basic safety requirements of EC Guidelines and state-of-the-art technology.
- The instrument is designed for use in grounded vehicles and machines as well as in pleasure boats, including non-classified commercial shipping.
- Use our product only as intended. Use of the product for reasons other than its intended use may lead to personal injury, property damage or environmental damage. Before installation, check the vehicle documentation for vehicle type and any possible special features!
- Use the assembly plan to learn the location of the fuel/hydraulic/compressed air and electrical lines!
- Note possible modifications to the vehicle, which must be considered during installation!
- To prevent personal injury, property damage or environmental damage, basic knowledge of motor vehicle/shipbuilding electronics and mechanics is required.
- Make sure that the engine cannot start unintentionally during installation!
- Modifications or manipulations to veratron products can affect safety. Consequently, you may not modify or manipulate the product!
- When removing/installing seats, covers, etc., ensure that lines are not damaged and plug-in connections are not loosened!
- Note all data from other installed instruments with volatile electronic memories.

SAFETY DURING INSTALLATION

- During installation, ensure that the product's components do not affect or limit vehicle functions. Avoid damaging these components!
- Only install undamaged parts in a vehicle!
- During installation, ensure that the product does not impair the field of vision and that it cannot impact the driver's or passenger's head!
- A specialized technician should install the product. If you install the product yourself, wear appropriate work clothing. Do not wear loose clothing, as it may get caught in moving parts. Protect long hair with a hair net.
- When working on the on-board electronics, do not wear metallic or conductive jewelry such as necklaces, bracelets, rings, etc.
- If work on a running engine is required, exercise extreme caution. Wear only appropriate work clothing as you are at risk of personal injury, resulting from being crushed or burned.
- Before beginning, disconnect the negative terminal on the battery, otherwise you risk a short circuit. If the vehicle is supplied by auxiliary batteries, you must also disconnect the negative terminals on these batteries! Short circuits can cause fires, battery explosions and damages to other electronic systems. Please note that when you disconnect the battery, all volatile electronic memories lose their input values and must be reprogrammed.
- If working on gasoline boat motors, let the motor compartment fan run before beginning work.
- Pay attention to how lines and cable harnesses are laid so that you do not drill or saw through them!
- Do not install the product in the mechanical and electrical airbag area!
- Do not drill holes or ports in load-bearing or stabilizing stays or tie bars!
- When working underneath the vehicle, secure it according to the specifications from the vehicle manufacturer.

SAFETY INFORMATION

- Note the necessary clearance behind the drill hole or port at the installation location. Required mounting depth: 65 mm.
- Drill small ports; enlarge and complete them, if necessary, using taper milling tools, saber saws, keyhole saws or files. Deburr edges. Follow the safety instructions of the tool manufacturer.
- Use only insulated tools, if work is necessary on live parts.
- Use only the multimeter or diode test lamps provided, to measure voltages and currents in the vehicle/machine or boat. Use of

conventional test lamps can cause damage to control units or other electronic systems.

- The electrical indicator outputs and cables connected to them must be protected from direct contact and damage. The cables in use must have enough insulation and electric strength and the contact points must be safe from touch.
- Use appropriate measures to also protect the electrically conductive parts on the connected consumer from direct contact. Laying metallic, uninsulated cables and contacts is prohibited.

SAFETY AFTER INSTALLATION

- Connect the ground cable tightly to the negative terminal of the battery.
- Reenter/reprogram the volatile electronic memory values.
- Check all functions.
- Use only clean water to clean the components. Note the Ingress Protection (IP) ratings (IEC 60529).

ELECTRICAL CONNECTION

- Note cable cross-sectional area!
- Reducing the cable cross-sectional area leads to higher current density, which can cause the cable cross-sectional area in question to heat up!
- When installing electrical cables, use the provided cable ducts and harnesses; however, do not run cables parallel to ignition cables or to cables that lead to large electricity consumers.
- Fasten cables with cable ties or adhesive tape. Do not run cables over moving parts. Do not attach cables to the steering column!
- Ensure that cables are not subject to tensile, compressive or shearing forces.
- If cables are run through drill holes, protect them using rubber sleeves or the like.
- Use only one cable stripper to strip the cable. Adjust the stripper so that stranded wires are not damaged or separated.
- Use only a soft soldering process or commercially available crimp connector to solder new cable connections!
- Make crimp connections with cable crimping pliers only. Follow the safety instructions of the tool manufacturer.
- Insulate exposed stranded wires to prevent short circuits.
- Caution: Risk of short circuit if junctions are faulty or cables are damaged.
- Short circuits in the vehicle network can cause fires, battery explosions and damages to other electronic systems. Consequently, all power supply cable connections must be provided with weldable connectors and be sufficiently insulated.
- Ensure ground connections are sound.
- Faulty connections can cause short circuits. Only connect cables according to the electrical wiring diagram.
- If operating the instrument on power supply units, note that the power supply unit must be stabilized and it must comply with the following standard: DIN EN 61000, Parts 6-1 to 6-4.

MECHANICAL INSTALLATION

WARNING

Before beginning, disconnect the negative terminal on the battery, otherwise you risk a short circuit. If the vehicle is supplied by auxiliary batteries, you must also disconnect the negative terminals on these batteries! Short circuits can cause fires, battery explosions and damages to other electronic systems. Please note that when you disconnect the battery, all volatile electronic memories lose their input values and must be reprogrammed.

BEFORE THE ASSEMBLY

1. Before beginning, turn off the ignition and remove the ignition key. If necessary, remove the main circuit switch

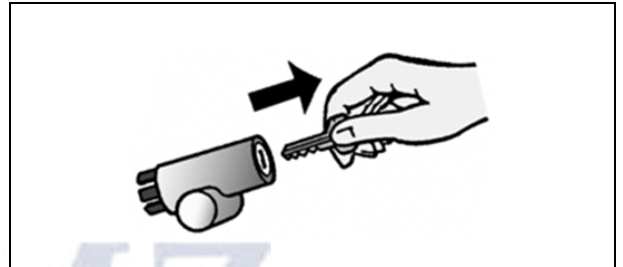

2. Disconnect the negative terminal on the battery. Make sure the battery cannot unintentionally restart.

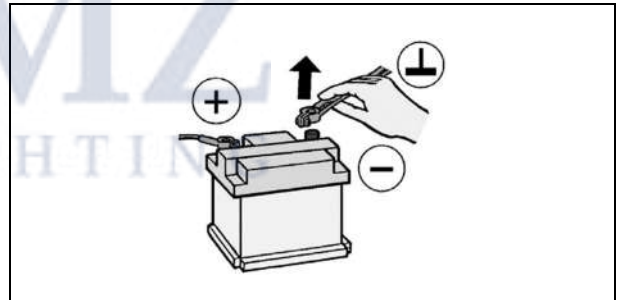

3. Place the device at least 300 mm away from any magnetic compass.

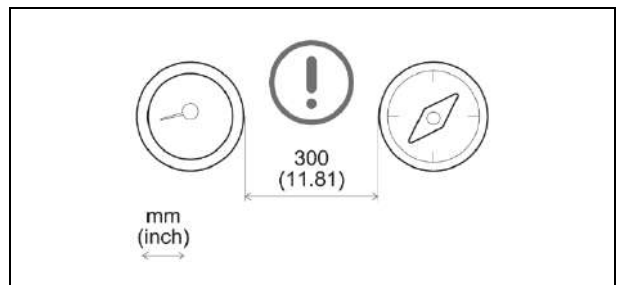

INSTALLATION WITH SPINLOCK

Conventional assembly. (Instrument is put into the drill hole from the front).

The panel width may be within a range of 0.5 to 20 mm. The drill hole must have a diameter of 53 mm [B].

⚠ WARNING

- Do not drill holes or ports in load-bearing or stabilizing stays or tie bars!
- Note the necessary clearance behind the drill hole or port at the installation location. Required mounting depth: 65 mm.
- Drill small ports; enlarge and complete them, if necessary, using taper milling tools, saber saws, keyhole saws or files. Deburr edges. Follow the safety instructions of the tool manufacturer.

1. Different bezels may be installed as alternatives to the supplied front ring. In this case, gently remove the bezel using a screwdriver [A] and install the new bezel on the instrument and press it on until it is flush with the instrument glass.

Note: the bezel cannot be used after removal since it can be damaged.

IMPORTANT: if installing a chrome bezel, make sure to configure the device **BEFORE** installing it, as the metallic particles contained in the chrome material might affect the NFC performance!

2. Create a circular hole in the panel considering the device dimensions. [B]
3. Remove the spinlock and insert the device from the front. [C]
4. Adjust the spinlock as shown in picture [D] according to the panel thickness
5. Carefully screw in the spinlock by hand at least two turns.
6. Insert the connector.

A

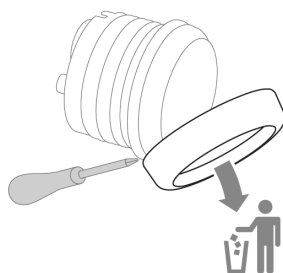

B

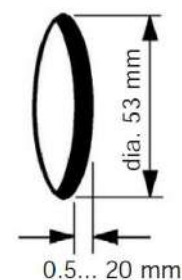

C

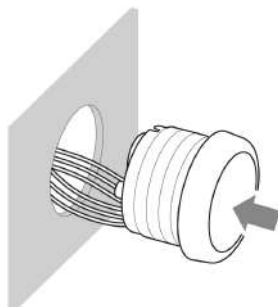

D

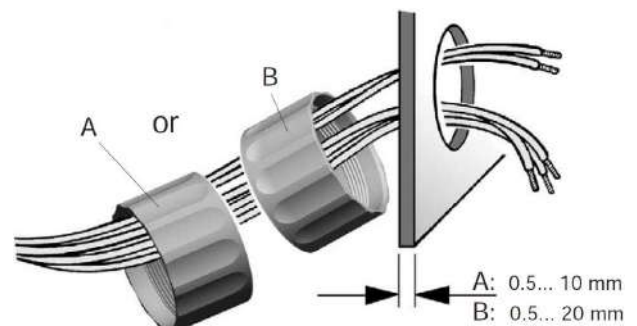

FLUSH MOUNTING

The recommended panel thickness is 1.5 to 3 mm. The drill hole must have a diameter of 48.1 mm. [A]
Ensure that the installation location is level and has no sharp edges.

 **WARNING**

- Do not drill holes or ports in load-bearing or stabilizing stays or tie bars!
- Note the necessary clearance behind the drill hole or port at the installation location. Required mounting depth: 65 mm.
- Drill small ports; enlarge and complete them, if necessary, using taper milling tools, saber saws, keyhole saws or files. Deburr edges. Follow the safety instructions of the tool manufacturer.

1. Create a circular hole in the panel considering the device dimensions. [A]
2. Remove the spinlock.
3. Gently remove the bezel using a screwdriver. [B]
Note: the bezel cannot be used after removal since damaged.
4. Place the flush mount seal A2C53215640 (not included) on the instrument glass.
5. Put the instrument into the drill hole from the back [C].
6. Adjust the instrument so that the gauge is level and fasten it to the stud bolts on the rear side of the panel, using the flush mount fixing bracket A2C59510864 (not included) [D].
7. Insert the connector.

A

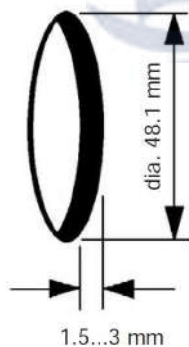

B

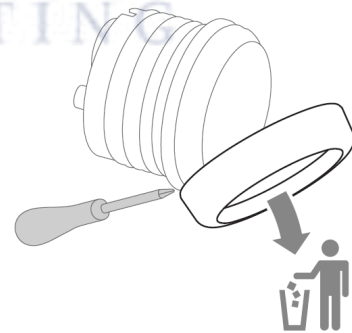

C

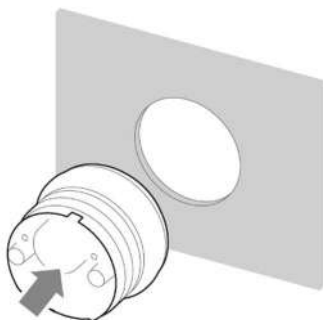

D

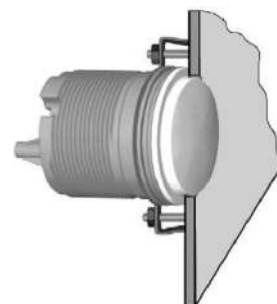

ELECTRICAL INSTALLATION

PINOUT

| Pin Nr. | Wire color | Description |
|---------|------------|--------------------------------|
| 1 | Red | KL.15 – Ignition Plus 12 / 24V |
| 2 | Black | KL.31 – Ground |
| 3 | White | Pushbutton input |
| 4 | Green | Level sensor input (resistive) |
| 5 | Violet | IBS Input (LIN 2.0 bus) |
| 6 | Pink | Illumination input (day/night) |
| 7 | - | n.c. |
| 8 | - | n.c. |

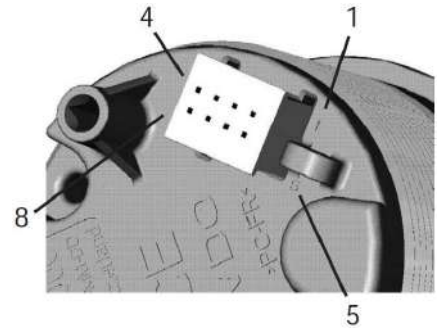

Instrument rear view
Tyco / Hirschmann 8 pole MQS plug

WIRING - 12V VARIANT

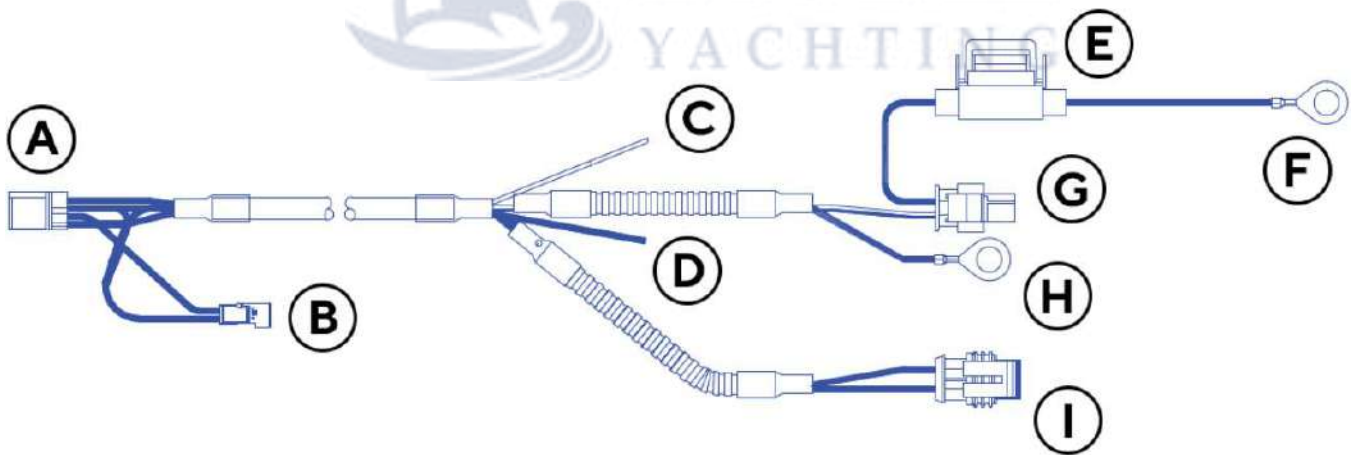

- A.** VL Flex 52 plug – Tyco / Hirschmann 8 pole MQS plug
- B.** Connector for push button
- C.** Wire for “day/night-signal” (pink)
- D.** Wire for 12V-Power supply (connect to ignition)
- E.** 3A fuse (water sealed)
- F.** Ring-type connector (red) – to batteries positive pole
- G.** 2-Pin Hirschmann Plug – for the IBS (872-863-561)
- H.** Ring-type connector (black) – to IBS’s negative pole terminal (M6 screw)
- I.** Resistive level sensor plug (AMP SuperSeal 1.5 series 2 Pin)

ELECTRICAL INSTALLATION

- A: IBS negative pole screw-on bolt (M8)
- B: IBS Hirschmann mating connector
- C: Positive pole terminal 12V (red wire)

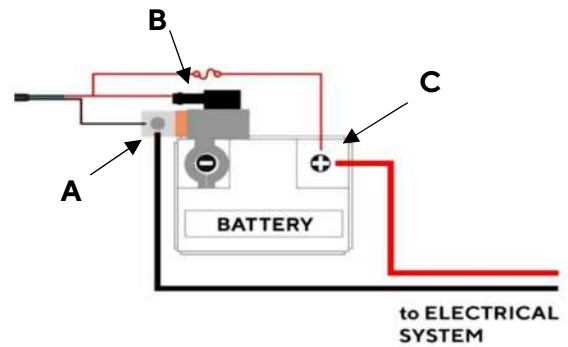

WIRING - 24V VARIANT

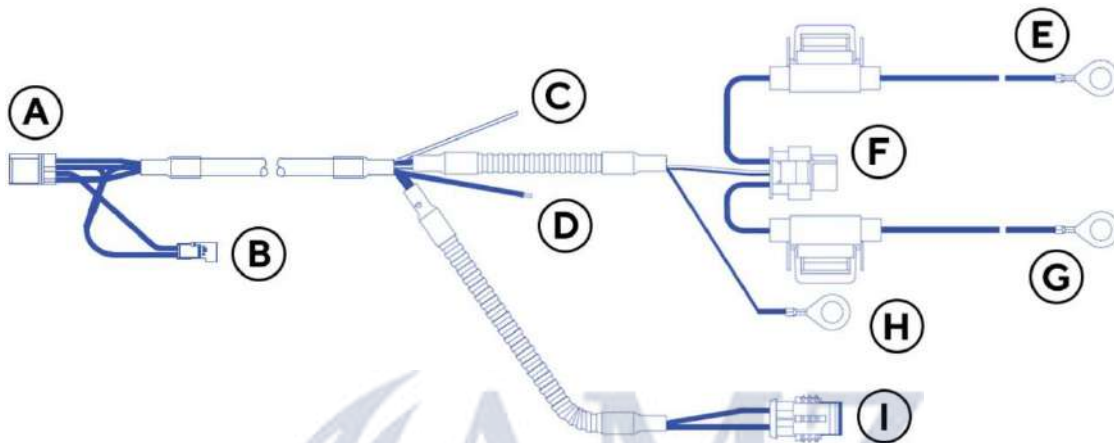

- A. VL Flex 52 connector - Tyco / Hirschmann 8-poles MQS plug
- B. Connector for pushbutton
- C. Wire for "day/night-signal" (pink)
- D. Wire for 12V-Power supply (connect to ignition) (red)
- E. Ring-type connector (red) with integrated 3A Fuse - to batteries positive pole (12V)
- F. 3-Pin Hirschmann Plug - for the IBS (872-858-546)
- G. Ring-type connector (brown) with integrated 3A Fuse - to batteries positive pole (24V)
- H. Ring-type connector (black) - to IBS's negative pole terminal (M8 screw)
- I. Resistive level sensor plug (AMP SuperSeal 1.5 series 2 Pin)

The 24V kit variant includes an additional brown wire on the harness with an integrated fuse.

This wire is required to allow the IBS to monitor the second 12V battery, which is connected in series to the first 12V battery to create the 24V.

It shall be connected to the positive battery pole with the higher potential (the 24V).

- A: IBS negative pole screw-on bolt (M8)
- B: IBS Hirschmann mating connector
- C: Positive pole terminal 12V (red wire)
- D: Positive pole terminal 24V (brown wire)

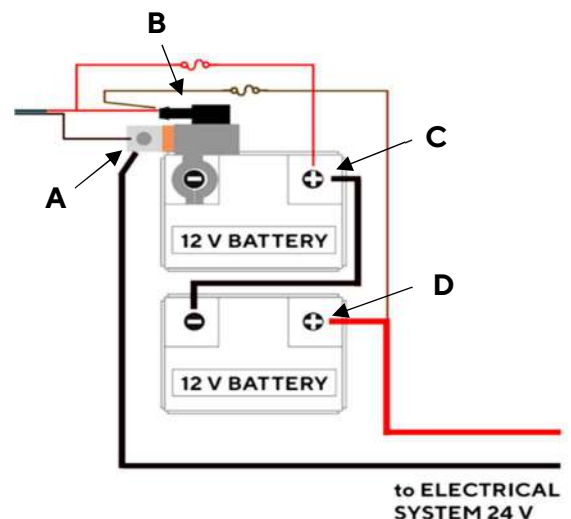

INSTALLATION GUIDE

 **WARNING**

Before beginning, disconnect the negative terminal on the battery, otherwise you risk a short circuit. If the vehicle is supplied by auxiliary batteries, you must also disconnect the negative terminals on these batteries! Short circuits can cause fires, battery explosions and damages to other electronic systems. Please note that when you disconnect the battery, all volatile electronic memories lose their input values and must be reprogrammed.

- The IBS has to be mounted and handled in an ESD protected area
- The IBS may not be contaminated with foreign particles (e.g. oil, silicon, grease, coolant, etc.)
- The IBS may not be damaged
- The pole clamp may only be torqued to the battery pole

Remove the ground cable and its clamp from the batteries negative pole.



Mount the wire harness' ground cable on the IBS ground bolt. Use the battery pole adapter to fasten the dedicated ring-type connector. Make sure not to damage the sensor while tightening the screw. (Check the note further below.)



Now mount the system ground cable (the one that has been attached directly to the battery before) onto the battery pole adapter on the IBS.



Note: During the mounting of the screw nut, the torque (max. 17 Nm) must be completely intercepted by an appropriate device/acceptance.

The torque must be intercepted only over the shore edges shown in the picture to the right.

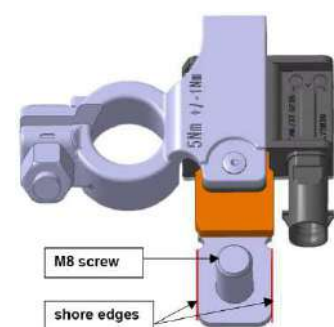

ELECTRICAL INSTALLATION

Mount as the next step the Intelligent Battery Sensor onto the negative pole of the battery.
Then fasten the IBS onto the battery pole clamp with a tightening force of 5 ± 1 Nm.
Use a torque key to adjust it to 5 Nm.

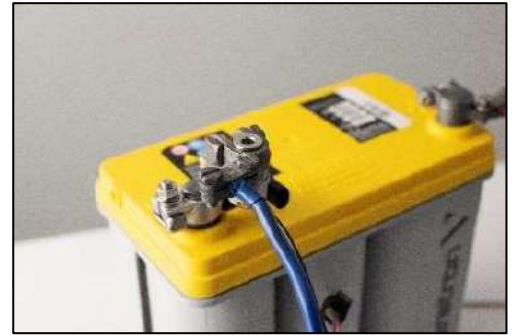

Connect the Hirschmann plug next to the black ring-type connector (2 poles for 12V-Variant/ 3 poles for 24V) to the battery sensor.

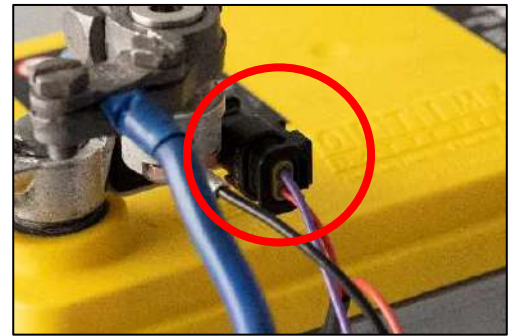

Connect the resistive level sensor plug (AMP SuperSeal 1.5 series 2 Pin) to the Level Sensor if there is one in your system.

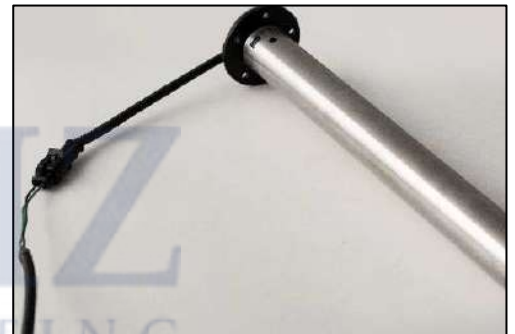

Connect the VL Flex 52 connector (Tyco / Hirschmann 8 pole MQS plug) to the instrument.



Use the 2-pole connector to connect the external pushbutton.

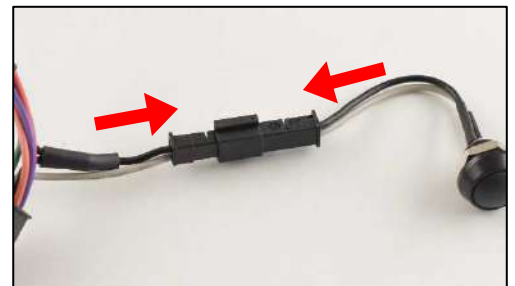

ELECTRICAL INSTALLATION

Now connect the red ring-type connector to the positive pole of the 12 V battery.

For this just clamp the ring under the screw nut, that's used to tighten the vehicles power cable to the batteries positive pole.

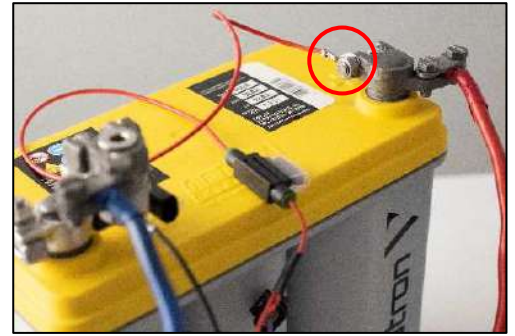

In addition for the 24V variant:

There is a brown wire with a ring-type connector next to the red one. Attach this to the positive pole of the second battery. Make sure that the wiring fits the schematic, shown on the right.

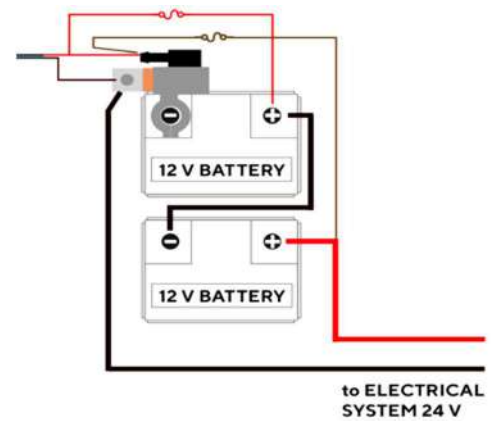

Connect the red wire to the ignition.

The installation of your IBM is now finished. If you switch on the ignition, the device should start up.

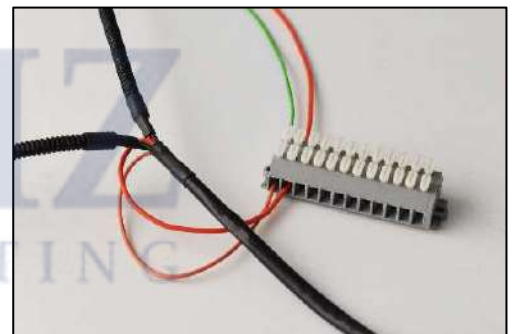

CONFIGURATION

INTELLIGENT BATTERY MONITOR APP

To configure the IBM system, some parameters must be calibrated, like the gauge type, the sensor and its calibration or the warning threshold.

This is possible through the “VL Flex Configurator” smartphone App, which can be downloaded free of charge from the stores of both Android and iOS devices.

A simple and detailed explanation of the configuration process is also available as in-app instructions.

Thanks to the passive embedded NFC receiver, the VL Flex 52 can be configured, as described below, without the need of a power supply.



INTELLIGENT BATTERY MONITOR



The setup of the VL Flex device is an intuitive three-step process.

Please remember that you must READ from the device before being able to change and download the configuration to the instrument.

1. READ

2. CONFIGURATE

3. WRITE



SYSTEM CONFIGURATION

1. READ THE VL FLEX CONFIGURATION

Launch the “Intelligent Battery Monitor” App and read the current configuration of the device by “tapping” the smartphone onto the front lens. The READ operation is mandatory before the WRITE operation is allowed.

After the readout, the App will be set with the current VL Flex configuration.

NOTE: The antenna position on the smartphone depends on the model. Please refer to the smartphone manufacturer manual.



2. CONFIGURE BATTERY PARAMETERS

Use the first box to define which IBS is used.

For the IBS Sensor to correctly work the type of battery must be defined. Use the second box to choose this parameter.

Write the batteries capacity in the last field of this section.

NOTE: The type of the battery and its capacity can be found printed on the batteries housing.

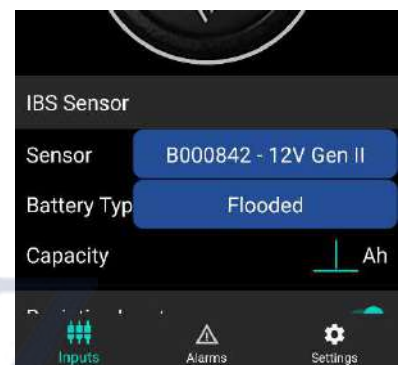

3. CONFIGURE THE LEVEL SENSOR (OPTIONAL)

Check the Resistive Input Switch in order to configurate the VL Flex according to your Level Sensor.

The first field is for defining, weather a Fuel Level Sensor or a Fresh Water Level Sensor is used.

In the second field you must choose the resistance values of the used sensor.

NOTE: The sensors resistor values depend on the Model. Please refer to the sensor manufacturer manual.

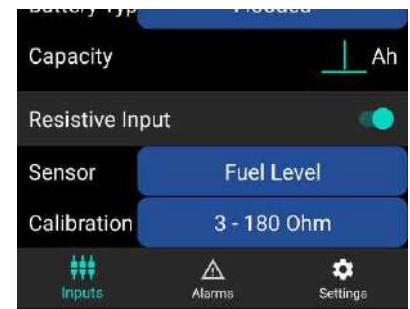

4. SETUP THE ALARMS

You can activate or deactivate the alarms by using the App switches.

Use the field next to the switch, to define the value, at which the alarm should be triggered.

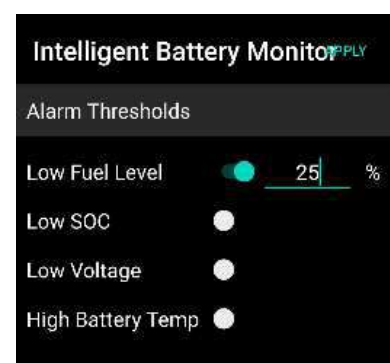

CONFIGURATION

5. CUSTOMIZE BACKLIGHT LEVELS AND UNITS

You can complete the VL Flex configuration with the "Settings" tab.

In this section it is possible to adjust the day and night backlight intensity through the dedicated App slider.

Here you can also choose your preferred unit for the temperature measurements. (Celsius or Fahrenheit)

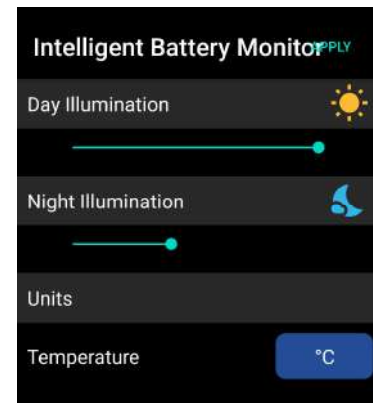

6. LOAD THE CONFIGURATION TO THE VL FLEX

Once the configuration is completed, you can transfer it to the VL Flex.

Press the "APPLY" button on the top/right corner of the App and near the smartphone again to the VL Flex lens as shown in picture.



SUPPORTED CONFIGURATIONS

| Sensor | Unit | Resistive Input | LIN-Bus Input | Calibrations | Alarm Available |
|----------------------------|--|-----------------|---------------|--|---|
| Intelligent Battery Sensor | % (SOC/SOH) V (Voltage) A (Current) °C/°F | - | ✓ | Flooded Gel AGM | Low SOC Low Voltage High Battery Temp. |
| Fuel Level | % | ✓ | - | 0 – 90 Ω 3 – 180 Ω 240 – 33 Ω 90 – 4 Ω 105 – 5 Ω | Yes |
| Fresh Water Level | % | ✓ | - | 3 – 180 Ω 240 – 33 Ω 90 – 4 Ω | No |

* the supported configurations may be updated at any time. Please make sure to always use the latest App version.

TIME FOR VALID SOC AND SOH

The values “State Of Charge” (SOC) and “State Of Health” (SOH) can only be considered valid after the sensor had a “quiescent” time of 3.5 hours after finishing the sensor installation.

“Quiescent” time means that the current consumption of the whole vehicle electrical system must be between -100mA and 0mA for the whole recalibration time (3.5 hours).

If there is a discharge peak during this time (e.g. radio turned on, etc.) the time for SOC recalibration will be longer than 3.5 hours.

If there is an additional power on of the IBS sensor (e.g. IBS disconnected from the battery, or from the Link Up gateway) then the recalibration time of 3.5 hours starts again.

EXTERNAL CHARGING OF THE BATTERY

If the battery is charged by an external power supply, it is important that the connection of the external charger is done properly.

If the connection is performed incorrectly, the IBS will not be able to measure the charge current and it will not calculate the SOC correctly.

Please connect the positive clamp of the charger to the battery pole and the negative clamp of the charger device to the IBS ground connection (where the vehicle ground is connected), and not directly to the negative pole of the battery.

The charging current must flow through the IBS so it can correctly determine the charge balance.

DISPLAY LAYOUT

SCREEN CAROUSEL

There are four different display layouts which can be scrolled through by pressing the push button.

With every push the display changes to the next screen showing the next set of values.

After the last screen, the display will roll over to the first one.

The fourth screen shows the data from the resistive level sensor if the analog input is activated.

The type of liquid (fuel or fresh water) must be configured on the VL Flex via the smartphone App during the system configuration.

If there isn't any sensor configured, the screen carousel only contains the first three screens.

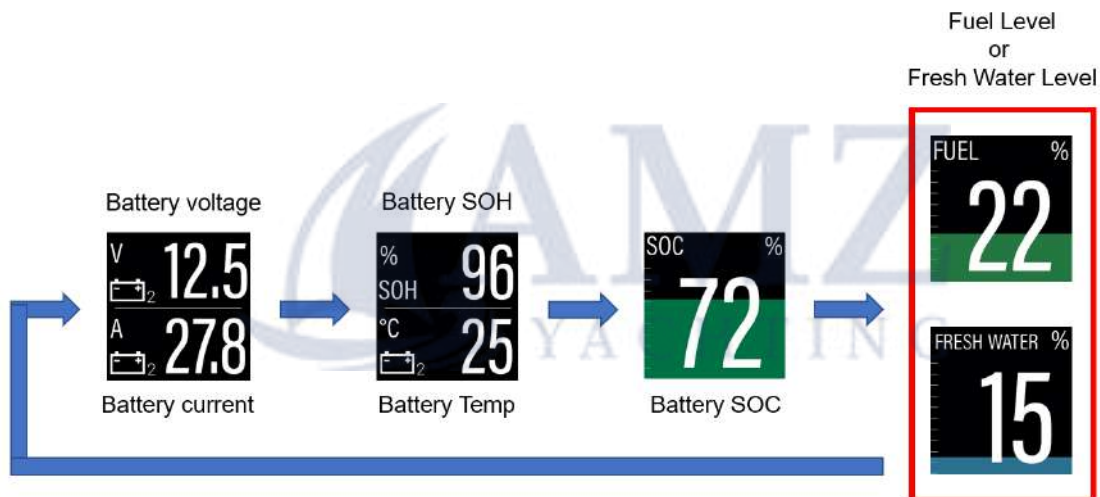

First Screen

On the upper half the batteries voltage is displayed. The unit is Volts.

On the lower half the current is displayed in Amps.

The little arrow indicates in which direction the current flows. If the battery is being charged the arrow appears in green. While it's red and pointing upwards during discharging.



Second Screen

The value on the top shows the State of Health (SOH). This value indicates in which condition the battery is due to influences like aging. (Which percentage of its initial capacity is still available.)

On the lower part the batteries temperature is indicated. The unit can be changed with the Intelligent Battery Monitor App.



Third Screen

The state of charge is displayed on the third screen. The percentage is displayed in numbers and there is a coloured graph in the background, visually representing this value.

The green lightning on the top middle part indicates that the battery is currently being charged. If it isn't the lightning will disappear.



Fourth Screen

On the last screen, the data from the resistive level sensor is displayed.

In the app you can configure whether your system contains a fuel level sensor, a freshwater sensor, or no sensor at all. In the last case the fourth screen won't be displayed, the screen will directly roll over to the first layout after the third.



CHARGE DISPLAY



Battery Charging Notification

When the battery starts being charged, this notification will pop up on screen to notify the charging.

This screen disappears after 2 seconds, and a charging symbol will be visible in the top side of the SOC screen.



Battery Discharging Notification

When the charging of the battery is interrupted, this notification will pop up on screen to notify the charging interruption.

This screen disappears after 2 seconds, and the display returns to normal operation mode.



ALARM DISPLAY



Single Data Layout

When an alarm occurs the bar-graph turns red and a red alarm symbol is displayed in the top part of the display between the data symbol and the unit.

The display returns to normal operation mode once the alarm is not detected anymore.



Dual Data Layout

When an alarm occurs on any of the two displayed data, the numeric digits of the affected data become red.

In the example above, the bottom data on screen (Exhaust Gas Temperature) has an alarm active.

The display returns to normal operation mode once the alarm is not detected anymore.

TECHNICAL DATA

DATASHEET

| | |
|-------------------------------------|---|
| Display | 1.44" sun-readable color TFT display, transmissive |
| Resolution | 125 x 125 pixels |
| Nominal Voltage | 12 V / 24 V |
| Operating Voltage | 8 – 32 V with overvoltage and reverse polarity protection |
| Current consumption | Typ. 50 mA with maximum backlight intensity |
| Maximum battery capacity | 500 Ah - with 12 V IBS (B000842) 255 Ah - with 24 V IBS (B000721) |
| Maximum permanent current | +/- 200 A |
| Maximum current (500ms peak) | +/- 1500 A - with 12 V IBS (B000842) +/- 2000 A - with 24 V IBS (B000721) |
| Analogue ports | Resistive (0 – 400 Ω) |
| Digital ports | LIN 2.0 (for Intelligent Battery Sensor) |
| Wireless interface | NFC (Near Field Communication) |
| Protection class | IP 67 front side acc. IEC60529 |
| Lens | PMMA with anti-glare and anti-fog treatments |
| Housing | Ø52 mm – Polycarbonate (PC), flame retardant acc. UL94-V0 |
| Bezels | PC (black, white) or ABS (chrome) – several color and shapes |
| Operating temperature | -20°C to +70°C |
| Storage temperature | -30°C to +80°C |
| Connector | Tyco / Hirschmann MQS connector 8 pins |
| Mounting | Spinlock Nut – locking height 0.5 – 20 mm Optional Studs and Brackets – locking height 2 – 15 mm |
| Compliance | CE, UKCA, Reach, RoHS |
| Display | 1.44" sun-readable color TFT display, transmissive |

ACCESSORIES

| Accessory | Part Number |
|-------------------------------|---------------|
| Wire harness for 12V system | B000868 |
| Wire harness for 24V system | B000869 |
| IBS Sensor 12 V | B00084201 |
| Pole adapter M6 (for 12V IBS) | B00068401 |
| IBS Sensor 24 V | B00072101 |
| Pole adapter M8 (for 24V IBS) | B00068201 |
| Spinlock Nut 52 mm | A2C5205947101 |
| Flush mount mounting kit | A2C59510864 |
| Flush mount seal | A2C53215640 |
| Bezel - Round Black | A2C5318602701 |
| Bezel - Round White | A2C5318602801 |
| Bezel - Round Chrome* | A2C5318602901 |
| Bezel - Triangular Black | A2C5318602401 |
| Bezel - Triangular White | A2C5318602501 |
| Bezel - Triangular Chrome* | A2C5318602601 |
| Bezel - Flat Black | A2C5318604001 |
| Bezel - Flat White | A2C5318602201 |
| Bezel - Flat Chrome* | A2C5318602301 |

Visit <http://www.veratron.com> for the complete list of accessories.

* the chrome bezel might interfere with the NFC programming due to the metallic particles contained in the chrome material. Make sure to configure the VL Flex device BEFORE installing the chrome bezel!



veratron AG
Industriestrasse 18
9464 Rüthi,
Switzerland

T +41 71 7679 111
info@veratron.com
veratron.com

Any distribution, translation or reproduction, partial or total, of the document is strictly prohibited unless with prior authorization in writing from veratron AG, except for the following actions:

- Printing the document in its original format, totally or partially.
- Copying contents without any modifications and stating Veratron AG as copyright owner.

Veratron AG reserves the right to make modifications or improvements to the relative documentation without notice.

Requests for authorization, additional copies of this manual or technical information on the latter, must be addressed to veratron AG.